

SCHEMATIC DIAGRAM-1

NOTE:
The number which noted at the connectors on the schematic diagram as "SCHEMATIC DIAGRAM-1" or "SCHEMATIC DIAGRAM-2" indicates the schematic diagram serial number located on the left corner in the schematic diagram.

▲ OPTICAL PICKUP

A CD SERVO CIRCUIT

→ : POSITIVE VOLTAGE LINE ⇨ : CD SIGNAL LINE

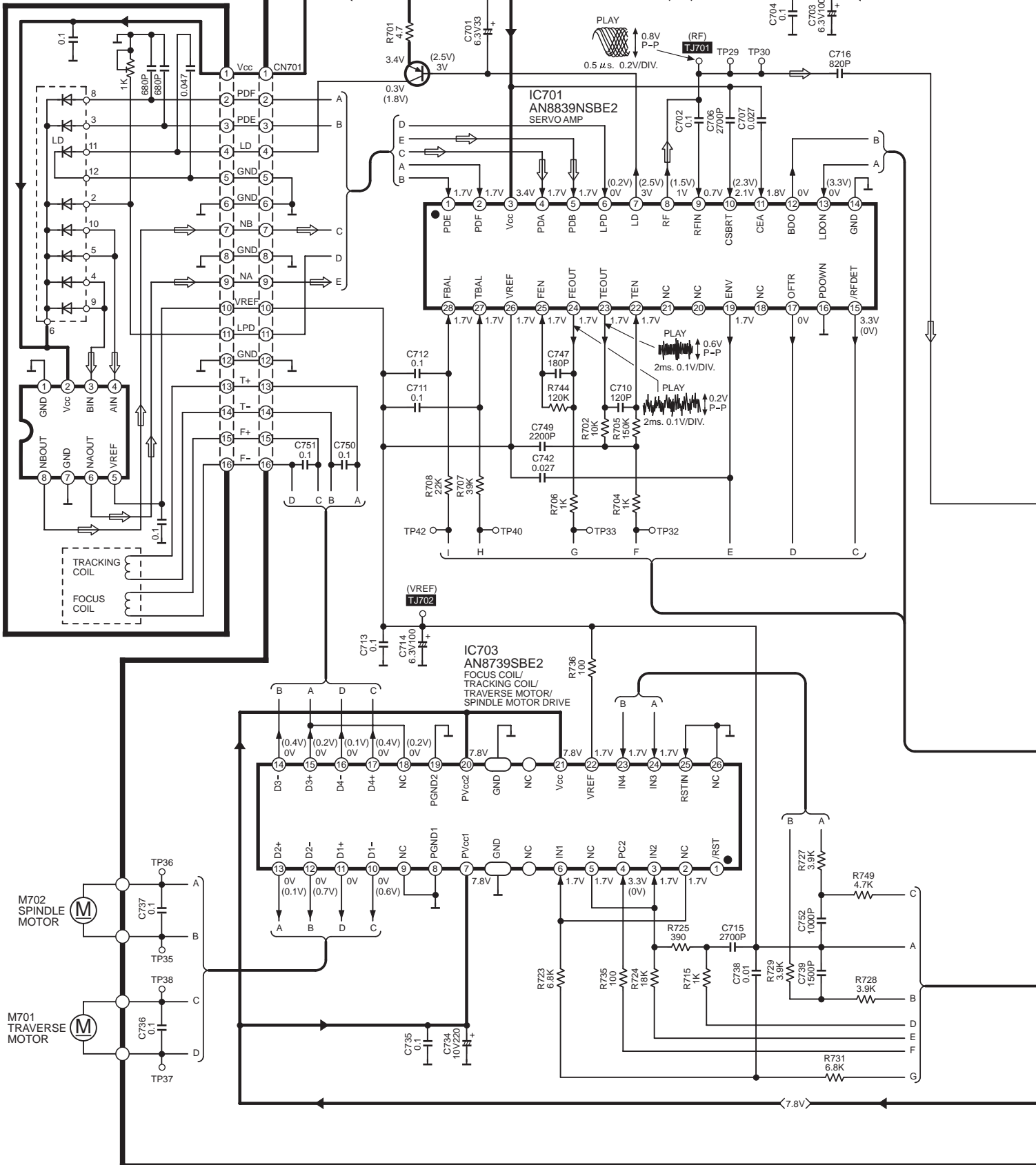

SCHEMATIC DIAGRAM-2

→ : POSITIVE VOLTAGE LINE ⇨ : CD SIGNAL LINE

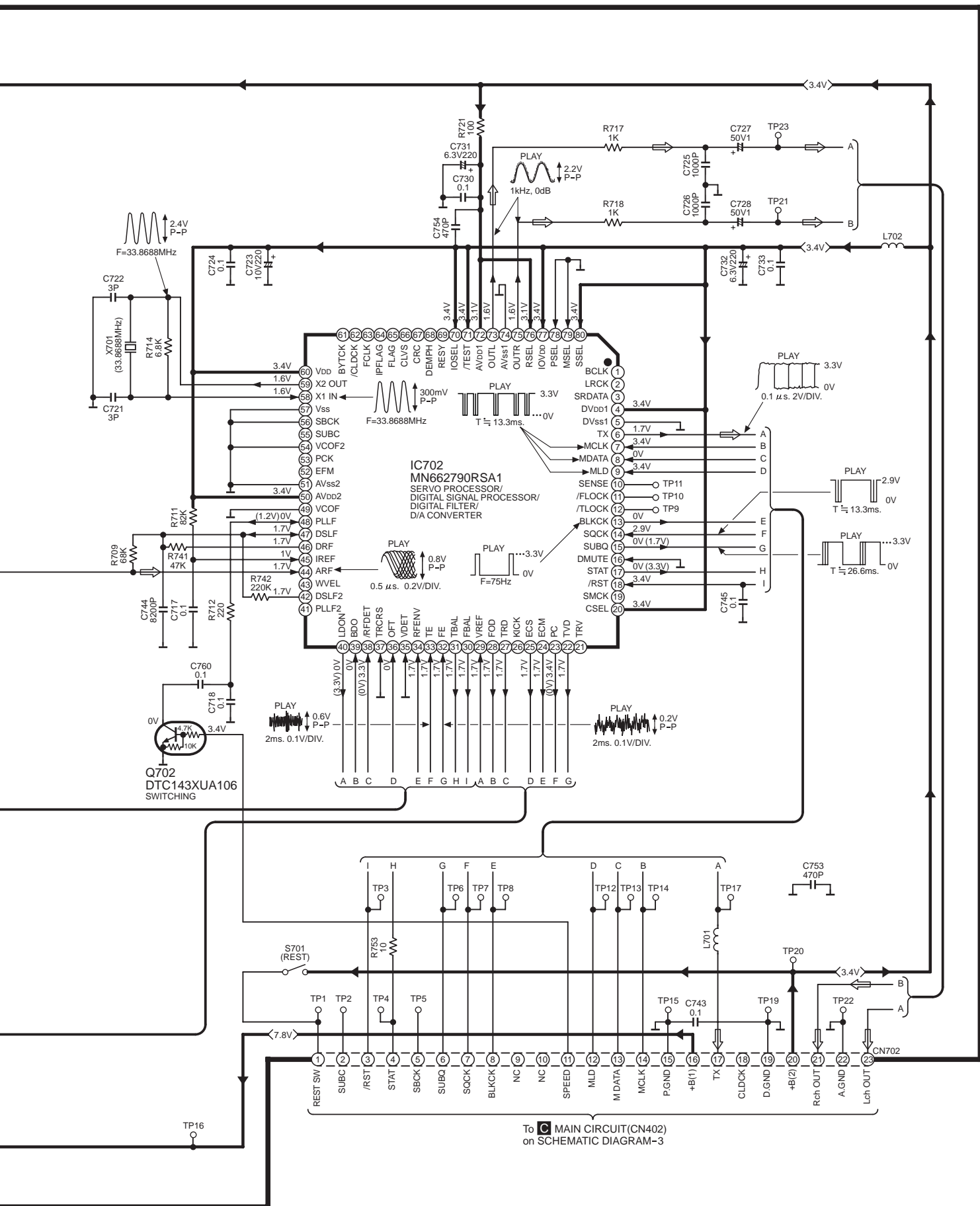

To MAIN CIRCUIT(CN402)
on SCHEMATIC DIAGRAM-3

C MAIN CIRCUIT

→ : POSITIVE VOLTAGE LINE ⇨ : CD SIGNAL LINE

B LOADING MOTOR CIRCUIT

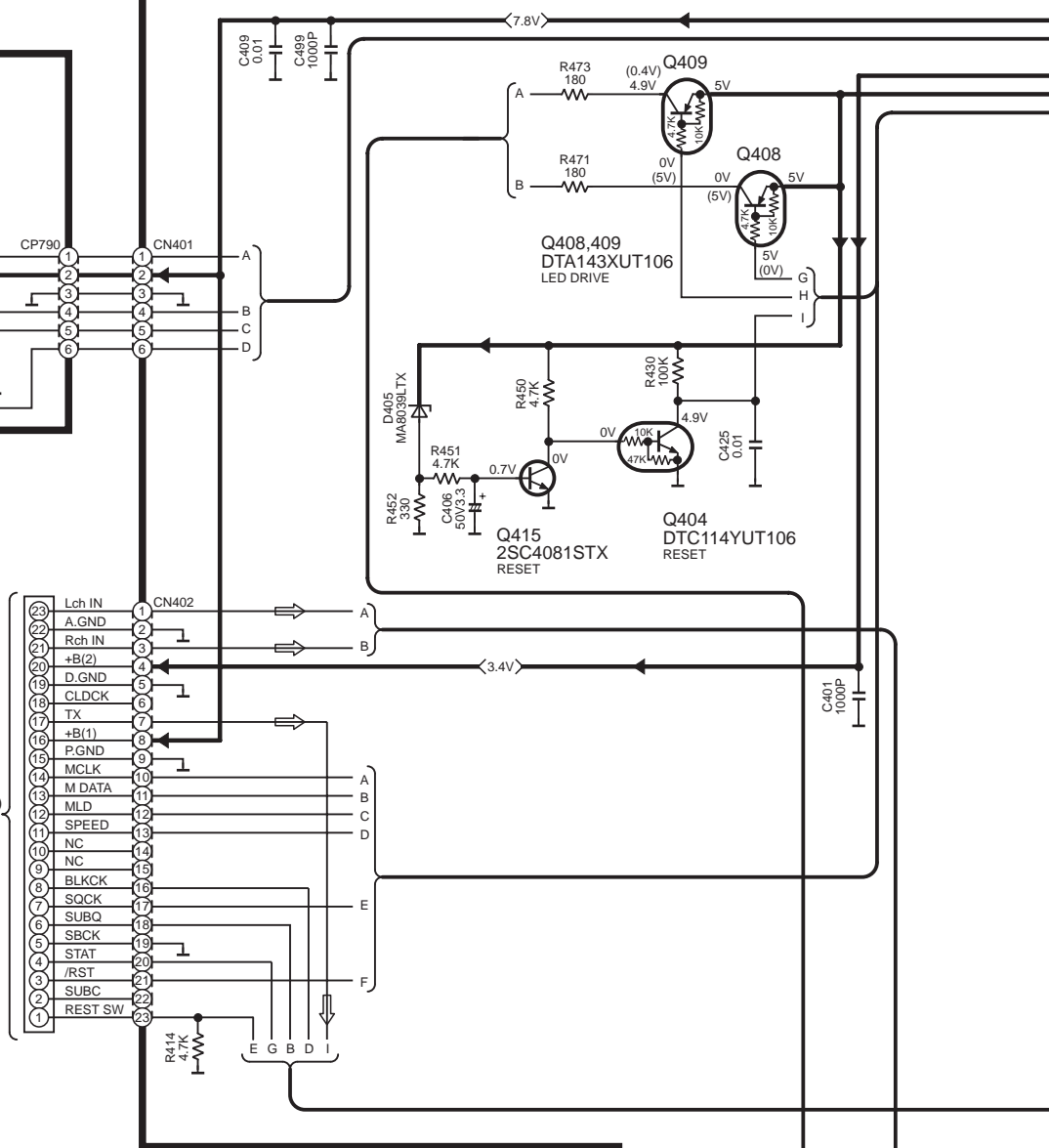
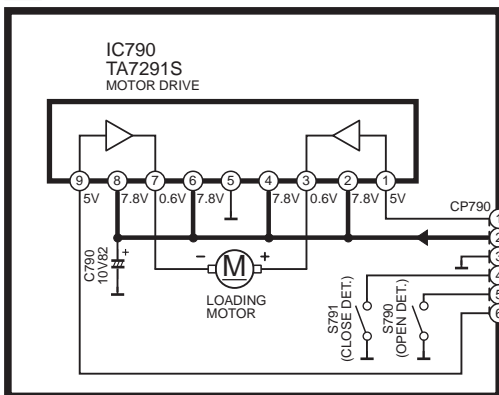

To **A** CD SERVO CIRCUIT(CN702)
on SCHEMATIC DIAGRAM-2

KEEPING TO THE RULE OF UNIT SUPPLY,
WE DO NOT SUPPLY SINGLE PARTS.

D OPERATION CIRCUIT

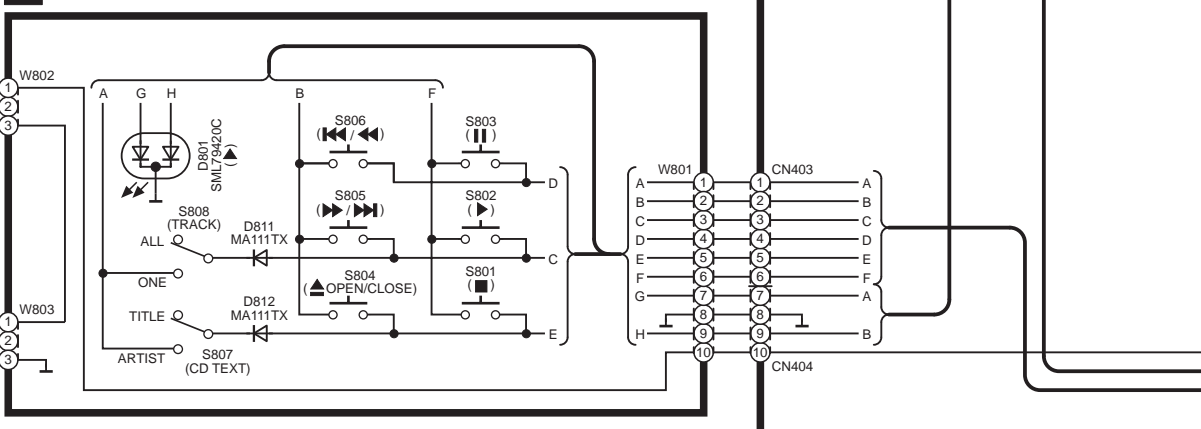
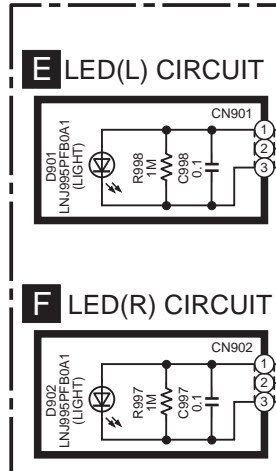

SCHEMATIC DIAGRAM-4

➔ : POSITIVE VOLTAGE LINE

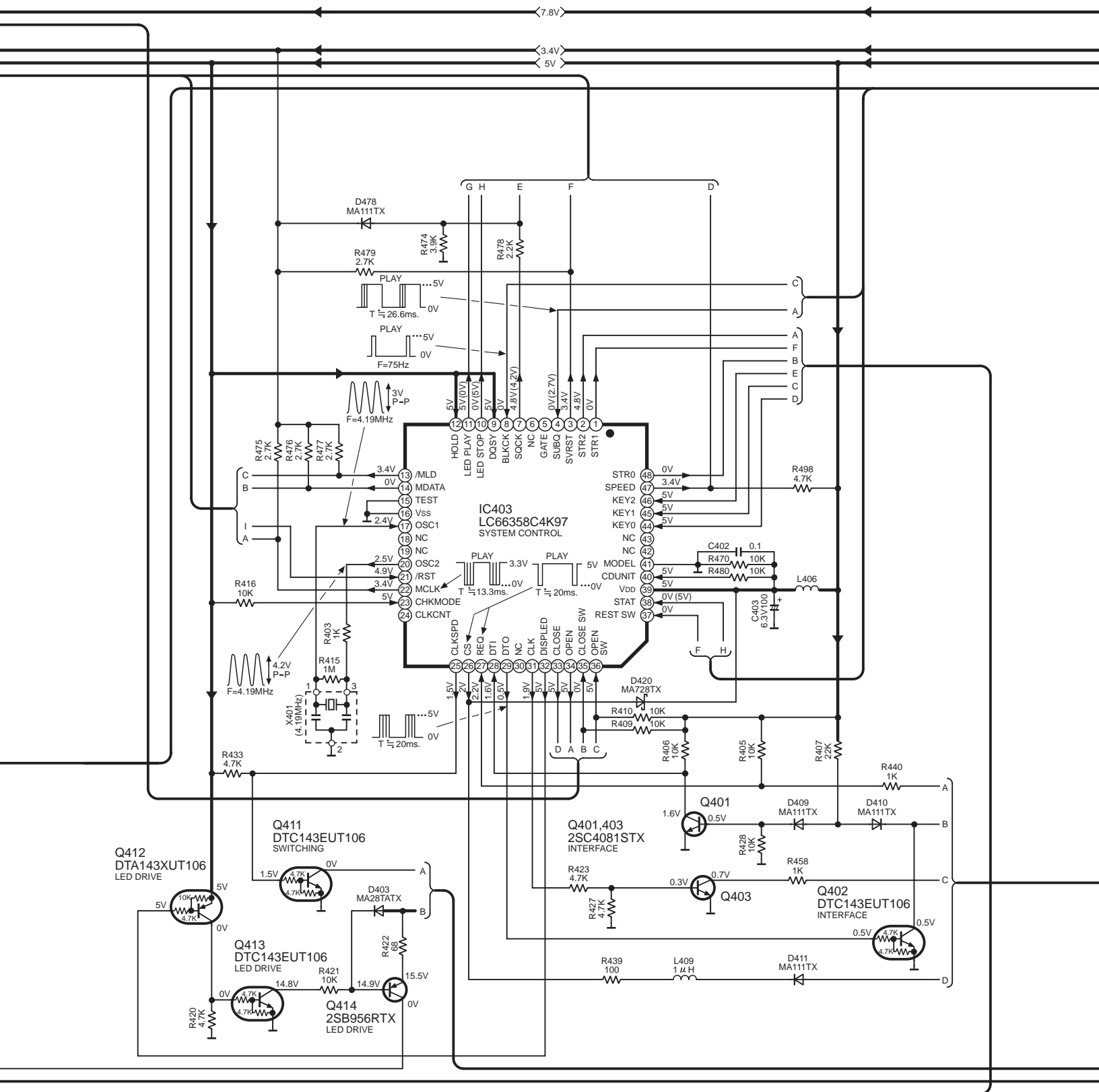

SCHEMATIC DIAGRAM-5

C MAIN CIRCUIT

→ : POSITIVE VOLTAGE LINE ⇨ : CD SIGNAL LINE

